

Smart-Encoder™: Resolver Absolute

1. Introduction

Autotech's Smart-Encoder possesses the following unique characteristics:

- User programmable resolver based absolute encoder
- Being field programmable, a single part number may replace many part numbers
- Programmable resolution up to 4096 counts per turn
- Programmable code format: BCD, Binary, and Gray
- User selectable wiring scheme (from the two available) for Binary and Gray codes
- Short circuit protected outputs
- Reverse polarity protected inputs
- Choice of Size 25 or 40
- NEMA 4, 4X, Submersible packages

The Smart-Encoder effectively eliminates multiple encoder part numbers by bringing intelligence and security to its design. In seconds, a four-digit LED display with two push-buttons enables the Smart-Encoder to change its resolution (counts per turn) and set a password to protect unauthorized changes eliminating the need for PCs or external devices for programming.

It is designed to operate within a wide range of industrial applications under harsh environmental conditions such as mechanical shock, vibrations, extreme temperature and humidity changes, oil mists, coolants and solvents. Nema 4 and 4x rated, submersible and explosion proof, Class 1, Div 1 models are also offered to suit a virtually limitless number of applications. The Smart-Encoder is available with the most common connectors found on the market making it a universal drop-in replacement for many brands of encoders.

Smart-Encoder™: Resolver Absolute

2. Specifications

ELECTRICAL

INPUT POWER

Voltage: 18-30 VDC
 Current: 250 mA @ 24 VDC exclusive of load High
 Voltage: Min. 2.4 VDC TTL Compatible Low Voltage:
 Max. 0.4 VDC TTL Compatible

OUTPUT DRIVERS

Line driver device: ET7272
 Voltage: $30V/V = 18-30VDC (V_{in} = V_{out})$ 30V/5= 5VDC
 Max Output Current: 40mA
 High Voltage: 30 VDC@ 20mA source current Low
 Voltage: 5 VDC @ 20mA sink current

OUTPUT FORMAT:

Gray Code/Gray Code Minus:
 Programmable up to 4096
Binary/Binary Minus:
 Programmable up to 4096
BCD: Programmable up to 1999

DATA SYNCHRONIZATION

Data Transfer input:
 HIGH: Position data continuously updated
 LOW: Position data latched at High to low transition and remains unchanged until input goes High again

PROTECTION

Reverse Voltage Protected Inputs
 Short Circuit Protected Outputs

POWER-ON SETTling TIME

Upon power-up the outputs are tri-stated for up to 100mSec.

ENVIRONMENTAL

Housing	Size 40 (4.0" dia.)	Size 40 explosion proof	Size 25 (2.5" dia.)
Max. Starting Torque @ 25 °C (oz. in.)	8(576.1)	8(576.1)	5(360.04)
Moment of Inertia (oz*in ²)	6.4 x 10 ⁻⁴	6.4 x 10 ⁻⁴	4.0 x 10 ⁻⁴
Max. Slew Speed (RPM)	5000	5000	5000
Shaft Size	5/8"	5/8"	3/8"
Max. Shaft Loading Axial and Radial:	120 lb.	120 lb.	80 lb.
Bearing Life at Max. Mfr. Spec.	2 x 10 ⁹	2 x 10 ⁹	2 x 10 ⁹
Shock	150g for 11ms		100g for 11ms
Vibration	20g to 2000Hz		20g to 2000Hz
Enclosure	NEMA 4/IP 66	NEMA 4x (Div1 , Class 1, Group B,C,D)	NEMA 4/IP 66
Operating Temperature	-10°C to 70° C		
Storage Temperature	-40°C to 85°C		

Smart-Encoder™: Resolver Absolute

3. Wiring

1. The shielded interconnecting cable should be routed in its own conduit and kept separate from other high voltages/high inductance wiring. The shield drain wire should be connected to earth ground at both ends of cable.

2. Follow the wiring diagram below:

CAUTION:

- Upon power-up the outputs are tri-stated for up to 100mSec.
- Check the cable wiring before applying power to the Smart-Encoder.

Mating Connector: Autotech's ECM-19REC-ITT

19-pin Connector

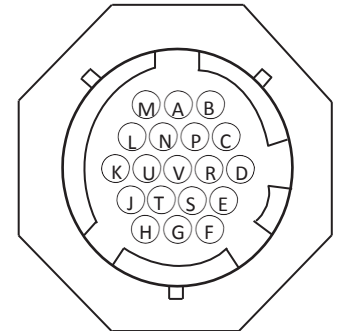
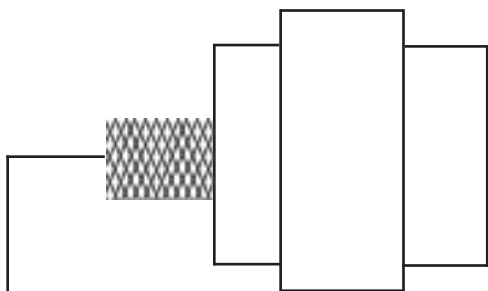

Cable: CBD-18S22-Mxxx

Connector Pin	Cable CBD-18S22 - Mxxx	Digital Outputs				
		BCD	Binary Type		Gray Code Type	
		<i>bcd</i>	<i>b in</i>	<i>b in-</i>	<i>Gr-Y</i>	<i>Gr-Y-</i>
A	Black	1	B11 (MSB)	B0 (LSB)	G11(MSB)	G0 (LSB)
B	White	2	B10	B1	G10h	G1
C	Grey	4	B9	B2	G9	G2
D	Violet	8	B8	B3	G8	G3
E	Blue	10	B7	B4	G7	G4
F	Green	20	B6	B5	G6	G5
G	Yellow	40	B5	B6	G5	G6
H	Orange	80	B4	B7	G4	G7
J	Red	100	B3	B8	G3	G8
K	Brown	200	B2	B9	G2	G9
L	White/Yellow	400	B1	B10	G1	G10h
M	White/Orange	800	B0 (LSB)	B11 (MSB)	G0 (LSB)	G11(MSB)
N	White/Brown	1000	Not Used			
P	White/Red	- V (Common)				
R	White/Green	Not Used				
S	Shield	Case Ground				
T	Black/12 gauge	- V (Common)				
U	White/Black	Data Transfer (PC sync)				
V	White/12 gauge	+ V (Supply VDC)				

Smart-Encoder™: Resolver Absolute

4. Mounting

Types of Mounting

1. Servo-Mount

The Smart-Encoder can be either mounted with traditional servo-clamps or through the four 6-32 mounting holes on the face of the resolver.

2. Flange-Mount

The Smart-Encoder can be mounted using the four mounting holes on the square face plate.

Mounting Dimensions

1. Size 40 Resolver Based (Face Mount) A40

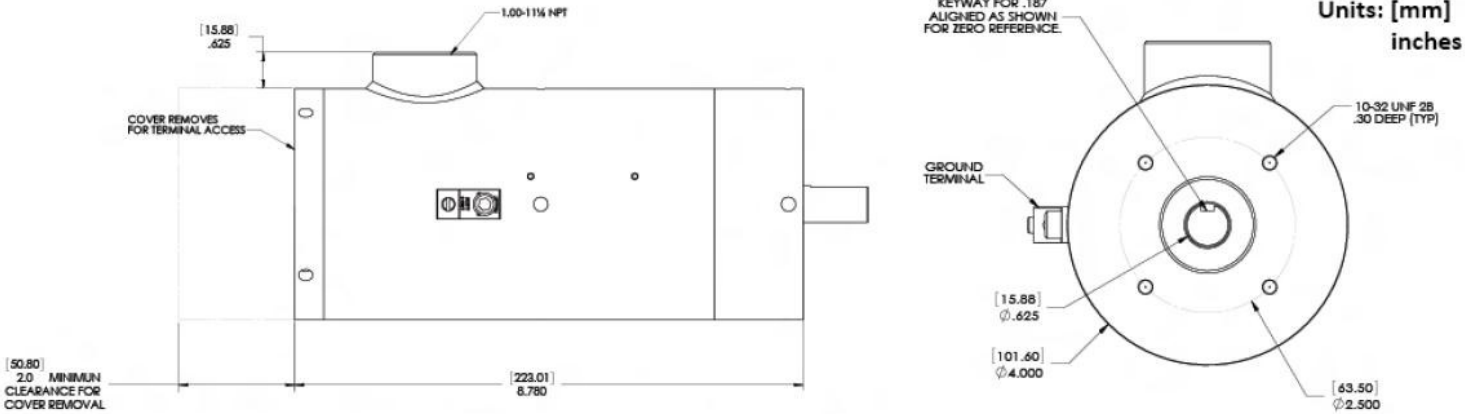

2. Size 40 Resolver Based (Face Mount)

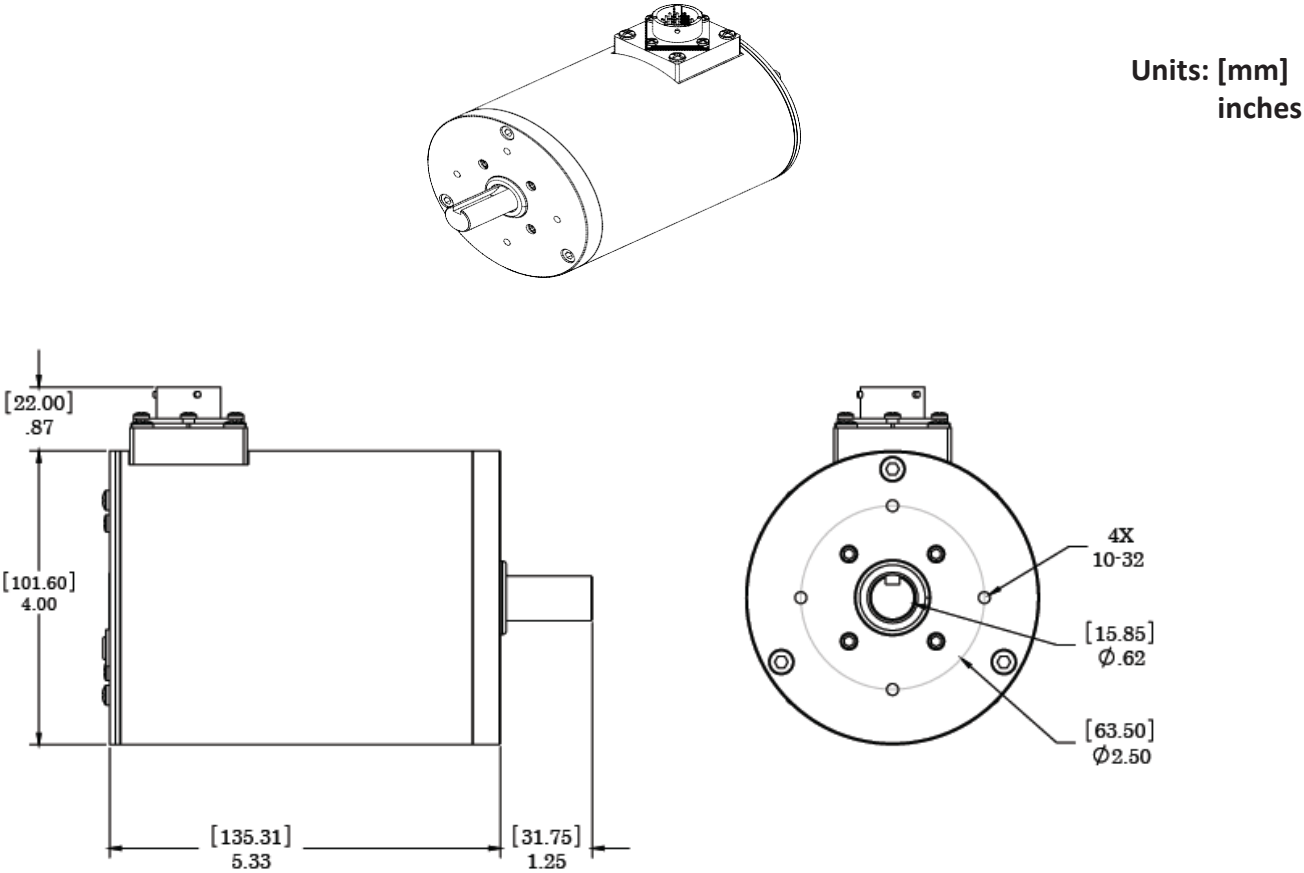

Smart-Encoder™: Resolver Absolute

3. Size 25 Resolver (Flange Mount)

Units: [mm]
inches

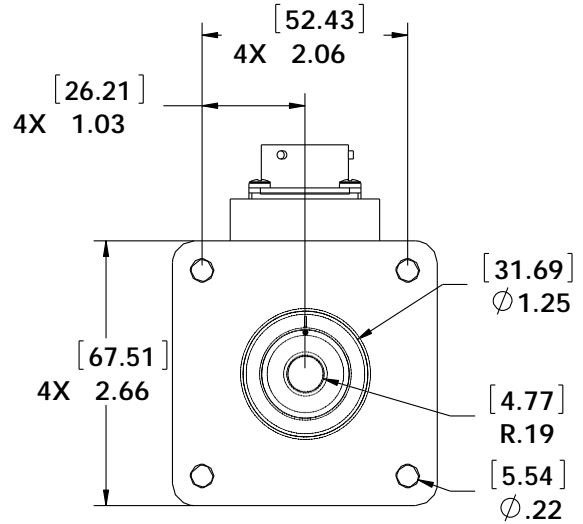
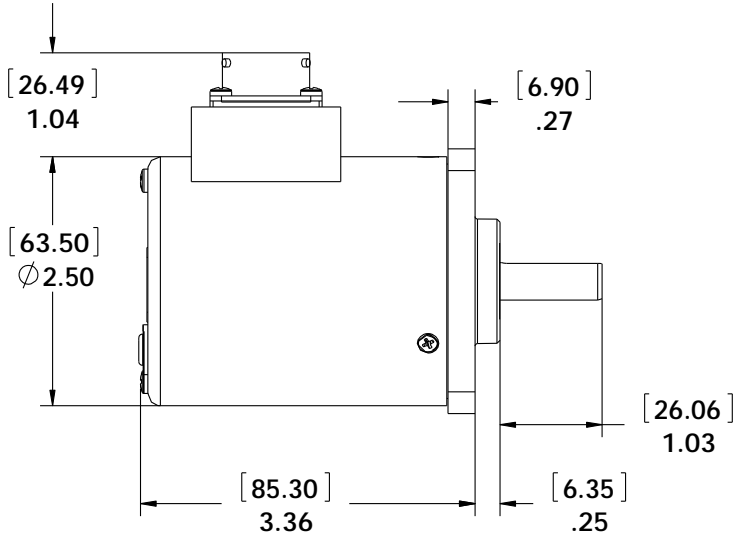
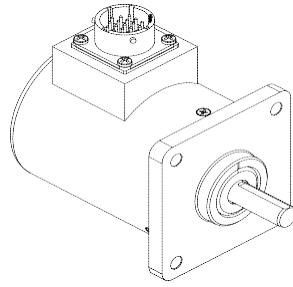

3. Size 25 Resolver (Servo Mount)

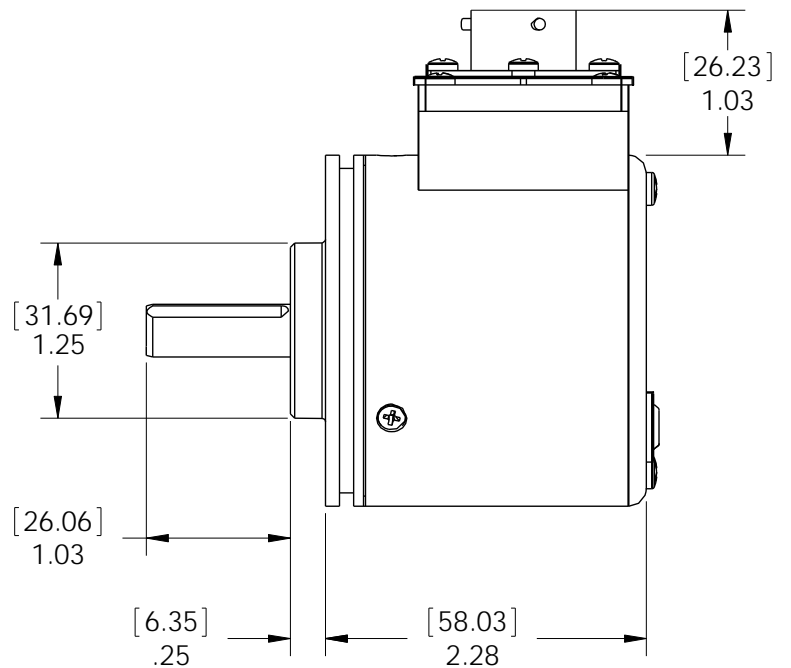
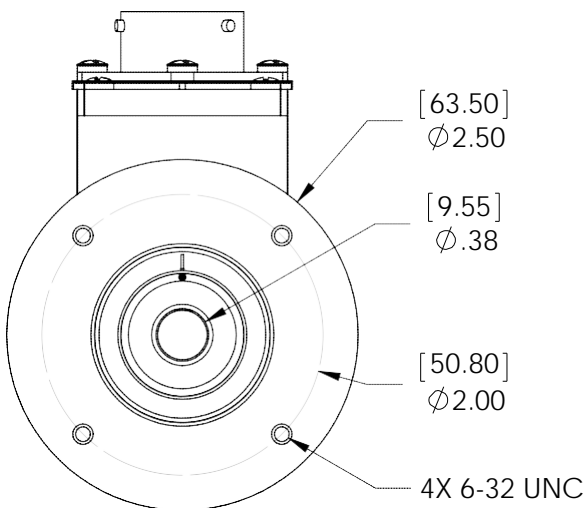

Smart-Encoder™: Resolver Absolute

5. How to Order

AXX – **RA** – **X** – **XXXX** – **S** – **XXXX** – **XX** – **XXX**
1 **2** **3** **4** **5** **6** **7** **8**

- | | |
|--|--|
| <p>1. Size
 25 2.5" Diameter
 40 4.0" Diameter</p> <p>2. Output Format
 RA Resolver Absolute</p> <p>3. Mounting
 F Flange Mount (Size 25)
 S Servo Mount (Size 25)
 A Face Mount, (Size 40)</p> <p>4. Input Power/ Output Driver (ET7272)
 30V/V 10-30Vin , Vin=Vout
 30V/5 10-30Vin , Vout =5V (TTL compatible)
 30V/N Single ended N type (current sinking)</p> <p>5. Output Connector Location
 S Side mount</p> | <p>6. Output Connector Type
 19SL 19pin MS Single Line Absolute</p> <p>7. Construction/ Housing
 AL Aluminum
 EX Explosion Proof (Size 40 Only)
 SS Stainless Steel, Water Submersible</p> <p>8. Gear Trains (Size 40 only)
 002 - 2:1 003 - 3:1 004 - 4:1
 005 - 5:1 008 - 8:1 010 - 10:1
 012 - 12:1 016 - 16:1 020 - 20:1
 024 - 24:1 032 - 32:1 038 - 38:1
 040 - 40:1 048 - 48:1 060 - 60:1
 064 - 64:1 080 - 80:1 100 - 100:1</p> |
|--|--|

Product Number Example: A25 – RA – F – 30V/5 – S – 10DL – AL

2.5" Diameter Encoder, Resolver Based Absolute, 5V Output Voltage, 19 pin MS Single Line Connector, Aluminum Housing.

Cable

CBD-18S22-Mxxx 18 Conductors (16 wires: 22 gauge, 2 wires: 12 gauge), overall foil shield with a 19-pin connector attached (where, xxx = length of the cable)

Smart-Encoder™: Resolver Absolute

6. Programming

The Smart-Encoder has a 7-segment LED Display (shown below) which can be used for programming the user parameters.

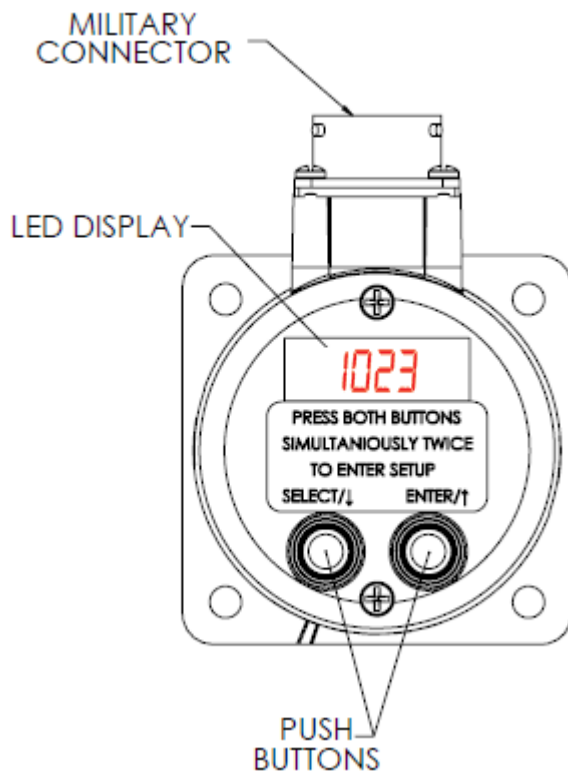

The Smart-Encoder has two (2) modes of operation **Run Mode** and **Programming Mode**.

1. Run Mode:

When in Run Mode the encoder will display the position or RPM (Revolutions Per Minute). To differentiate between the two parameters, the Resolver includes a decimal point following the right-most digit while displaying the RPM.

Left Pushbutton:

Pressing the Left Push button in run mode toggles between the position and RPM display.

Right Pushbutton:

Pressing the Right Push button in the run mode provides the user with a quick overview of the Encoder's Resolution setting and the Firmware Version. After automatically scrolling through the values, the display returns to the Run Mode. These parameters are:

RUN MODE	EXAMPLE
Position	2473
RPM	0311.

- uEr* - Firmware Version
- PSEt* - Position Set
- rES* - Resolution
- tYPE* - Type of code
- dl r* - Direction of rotation

Smart-Encoder™: Resolver Absolute

2. Programming Mode

- To enter the programming mode, press both of the push buttons simultaneously twice.
- Use the left push button to navigate through the parameters to be set.
- Use the right push button to select the parameter to be programmed.
- Use left push button to decrement and the right to increment values.
- Press both of the push buttons simultaneously to save the changes, program the flash and return to “Programming Mode” (all done in one step).
- After 10 sec. of inactivity in Programming Mode, the Encoder will discard the changes and go back to Run mode.

The following parameters may be programmed on the Smart-Encoder:

Main Menu		
1	Reset	rESt
2	Position Set	PSEt
3	Resolution	rES
4	Output Format	tYPE
5	Direction	dIr
6	Password Set	PASS

* If a password has been previously set, upon entering the programming mode the user is immediately prompted to enter the password. The LED display shows **PASS** momentarily and then **0000**. The left push button decreases the value while the right push button increases it. Once the desired value is set, press both pushbuttons simultaneously to enter password.

- If an incorrect password is entered, the display prompts for the password once more.
- If an incorrect password is entered again, the display shows **bAd** briefly and then returns to Run Mode.

Reset

In **rESt** mode, the display flashes the actual (scaled) offset and then displays **ZErO**. Pressing both push buttons at this time will set the current position of encoder to zero, and brings the Smart-Encoder back to the Programming menu.

Position

In **PSEt** mode, the LED display shows the actual (scaled) position. The left push button decrease the value while the right push button increases the value. Pressing both push buttons simultaneously saves the current position value and bring the Smart-Encoder back to the Programming menu.

Resolution

In **rES** mode, the encoder displays the current resolution (counts per turn). The left push button decrease the value while the right push button increases the value. Pressing both push buttons simultaneously saves the current resolution and brings the Smart-Encoder back to the Programming menu.

Note: For Binary/Binary Minus and Gray Code/Gray Code Minus, the maximum programmable resolution is 4096. For BCD, the Resolution can be programmed up to 1999.

Output Format

In **tYPE** mode, the encoder displays the current type of output format. To maintain compatibility with various manufacturers’ requirements, we offer five types of outputs to choose from:

- bin** = Binary (bin)
- bin-** = Binary Minus (bin-)
- bcd** = BCD
- gry** = Gray Code (gry)
- gry-** = Gray Code Minus (gry-)

Please refer to the table on page 3 for the differences in bit structure between Binary or Gray and Binary- and Gray-. Pressing any one of the push buttons cycles through the available output formats. Pressing both push buttons simultaneously saves the current output format and proceeds to **rES** mode. Refer to “Resolution” programming above to set the desired counts per turn.

Smart-Encoder™: Resolver Absolute

Direction

In **d ir** mode, the encoder display the current direction of ascending count: **CU** (clockwise) or **CCU** (counter clockwise). Pressing both push buttons simultaneously saves the direction and brings the Smart-Encoder back to the Programming menu.

Password

In **PASS** mode, the encoder displays **On** to indicate a password has been set or **oFF** to indicate password feature is disabled.

Pressing any one of the push buttons toggles between password “on” and “off”. To disable password feature choose **oFF** and press both push buttons simultaneously. The encoder will then return to Run Mode. To enable password protection choose **On**. The encoder then shows the current password stored in memory. The right push button increases the value while left push button decreases it. When the desired value has been selected, pressing both the push buttons simultaneously saves the new password, and returns the Smart-Encoder to Run Mode.

3. Programming Example

This example will illustrate how to program the encoder with the following parameters: a resolution of 360 pulses per revolution, binary type outputs, counter clockwise direction for ascending count, and a password set to “1111”.

- a. Wire the encoder according to the wiring instructions on page 2 and supply the appropriate power.
- b. The encoder is now in Run Mode. You may press the left push button to see the RPM while rotating the shaft of the encoder.
- c. Press both push buttons twice simultaneously to enter Programming Mode. The LCD display will now show the first programming screen: **rESt**.
- d. To set the output type press the left push button three (3) times to navigate to **tYPE**. Press the right push button to enter the Output Type set mode. Press the left button until you see **b in**. Now press both push buttons simultaneously to save.

e. The current resolution will now be displayed. Using the left push button decrement the count to **0360**. Press both push buttons simultaneously to save.

f. The screen will now display **d ir**. Press the right push button to enter set mode for the direction. Using either push button toggle the direction to **CCU** and then press Left and Right push button simultaneously to save.

i. The screen will now display **0000**. Using the right push button, increment the password to **1111**. Press both push buttons to save the password.

h. The encoder will now return to Run Mode.

This completes the programming example. You may check the parameters by pressing the right push button while in run mode.

*For instructions on resetting the password, please consult the factory.

Smart-Encoder™: Resolver Absolute



4. Programming Flowchart

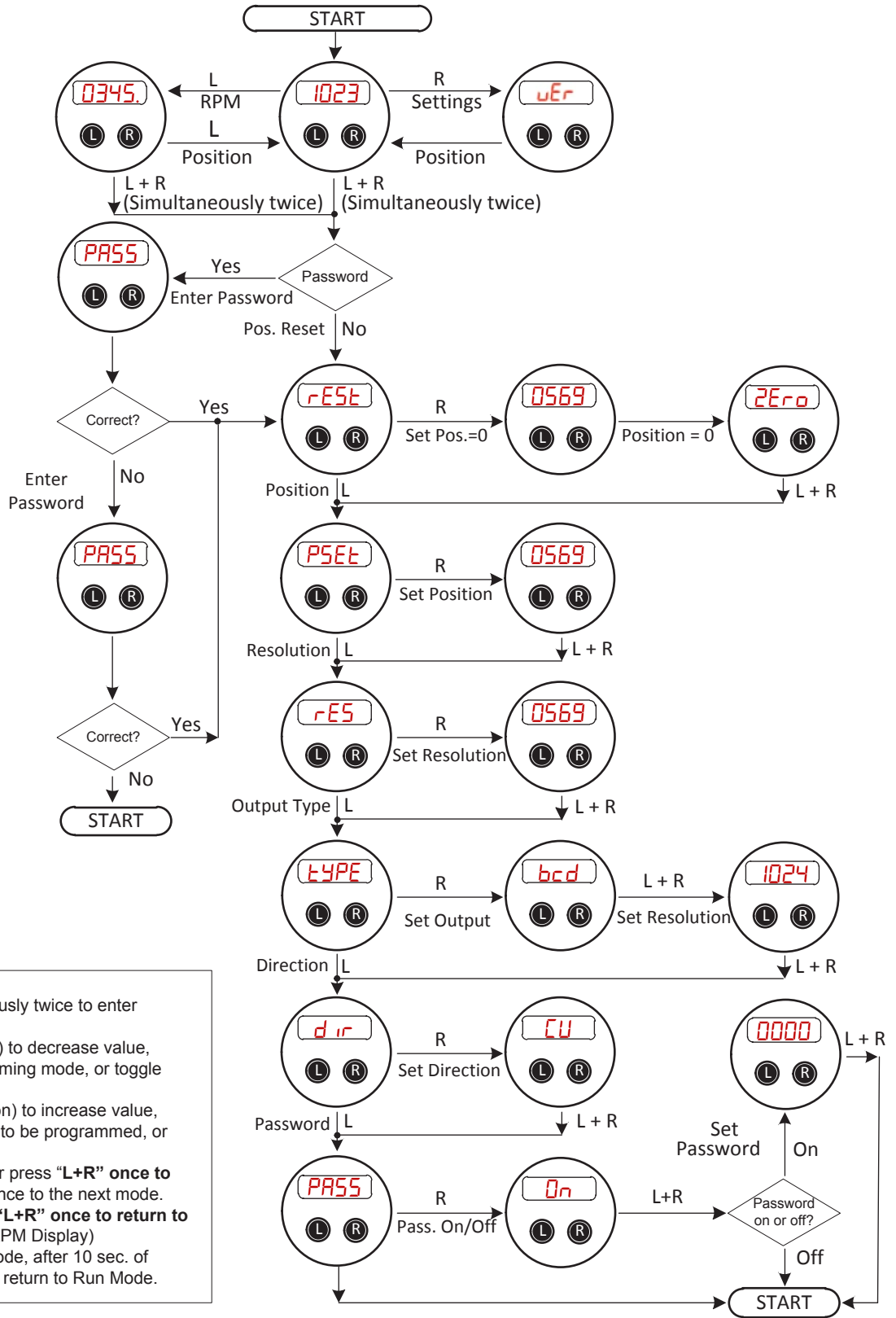

- NOTES**
- Press "L + R" simultaneously twice to enter programming mode.
 - Use "L" (left push button) to decrease value, advance to next programming mode, or toggle settings.
 - Use "R" (right push button) to increase value, select the current setting to be programmed, or toggle settings.
 - While setting a parameter press "L+R" **once** to **save changes** and advance to the next mode.
 - While navigating, **press "L+R" once** to **return to Run Mode** (Position or RPM Display)
 - While in programming mode, after 10 sec. of inactivity the encoder will return to Run Mode.

